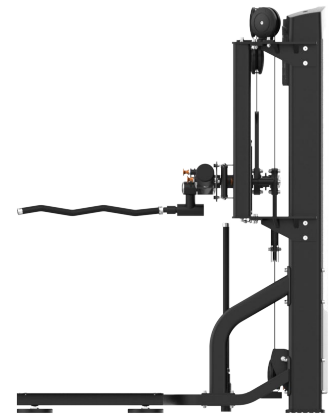
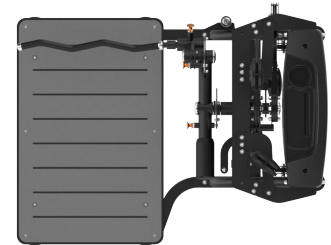

RE80 SELECTORIZED SERIES**RE8041 - STANDING TOTAL ARMS****PRODUCT OVERVIEW**

The RE8041 is a dual-function, premium selectorized strength machine engineered specifically for upper arm training. With its modern aesthetics, robust construction, and refined craftsmanship, it is ideal for large commercial gyms and high-end personal training studios.

Featuring 13 arm position adjustments, it fully accommodates a wide range of biceps curl and triceps extension variations, effectively engaging all elbow flexion and extension muscle groups. Four arm length settings precisely match different forearm lengths, aligning the user's pivot point with the machine's pivot point for improved power transfer and smoother motion. Ten arm height adjustments cater to users of varying statures, ensuring optimal ergonomics and training comfort.

Equipped with 360° rotating handles, the RE8041 adapts to the movement path in real time, helping users maintain a neutral wrist position to reduce joint stress while enhancing stability and control. The wide, non-slip foot platform offers a solid base during heavy lifts, keeping the body synchronized with the machine to prevent unwanted movement, maximize safety, and ensure consistent performance.

SPECIFICATIONS & KEY FEATURES

Specifications

Dimension:	1377*1075*1800mm
Total Weight:	288kg
Weight Stack Options:	80kg
Maximum Weight Stack:	80kg
Main Frame Tubing:	PT50×100×2.5
Target Muscle Groups:	Biceps ,Triceps
Standard Color Scheme:	Powder-Coated Color 2852-1

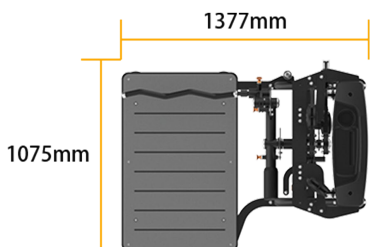
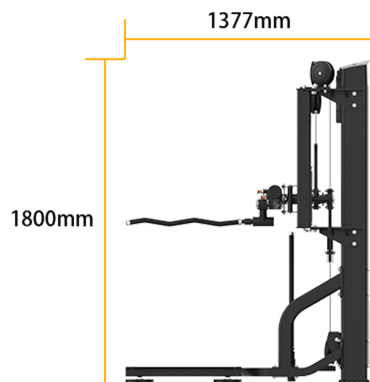
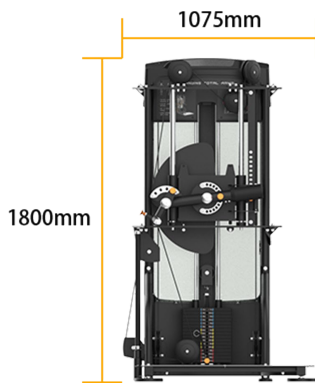

Product Features

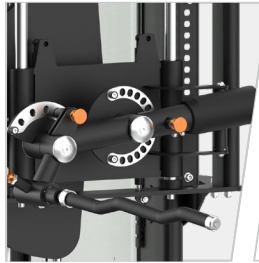

Dual-Function Design

13 arm position adjustments cover both biceps and triceps training, effectively targeting all elbow flexion and extension muscle groups.

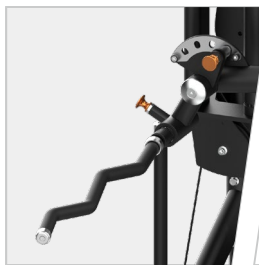

Four Arm Length Settings

Precisely adapt to different forearm lengths, ensuring accurate pivot alignment for better power transfer and smoother execution.



Ten Arm Height Adjustments

Accommodate users of varying heights for optimal ergonomics, comfort, and movement efficiency.

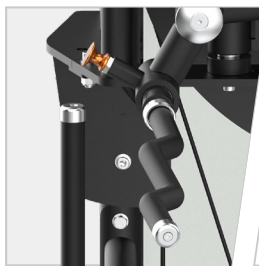

360° Rotating Handles

Adapt to the movement path, maintain a neutral wrist position, and reduce joint stress.



Interchangeable Grip Options

Includes straight bar and cambered bar for versatile grips and comprehensive muscle activation.



Wide Non-Slip Foot Platform

Provides secure support during heavy training, minimizing machine sway and ensuring both safety and performance.