

RE80 SELECTORIZED SERIES**RE8006 - BICEPS CURL****PRODUCT OVERVIEW**

Sculpt mountain-peak biceps with this revolutionary machine! The innovative dual-pivot point design perfectly matches elbow joint movement patterns. The unique arm pad angle effectively reduces deltoid compensation, focusing force directly on the biceps. The dual-handle system enables both reverse and hammer grip variations, ensuring comprehensive muscle development.

SPECIFICATIONS & KEY FEATURES

Specifications

Dimension	1478*1151*1602mm
Total Weight:	224kg
Weight Stack:	105kg
Max Weight Stack:	117.5kg

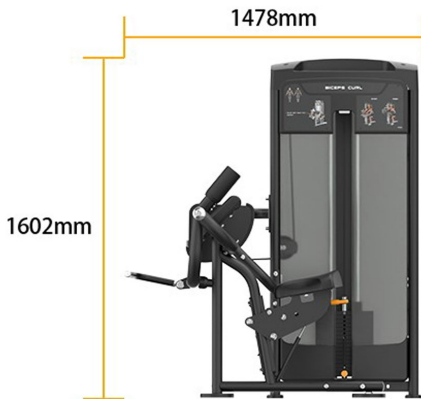
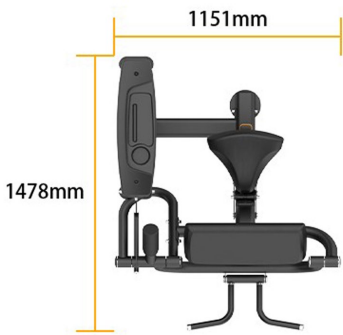
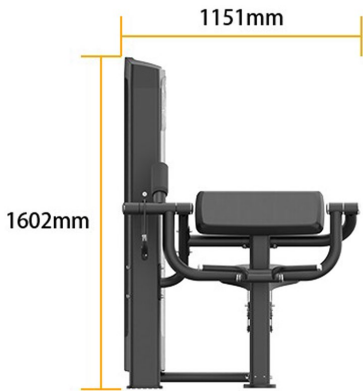

Product Features



Dual-Pivot System, Redefining Joint Movement

The breakthrough dual-pivot design exemplifies the golden ratio of biomechanics. Regardless of forearm length, users experience optimal training feel. Every curl motion precisely follows the elbow joint's natural movement pattern, effectively reducing joint shear forces.

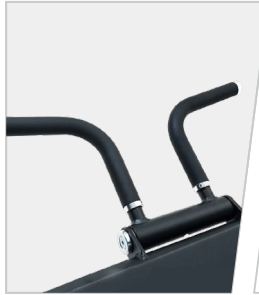

Dual-Grip Design, Complete Muscle Coverage

Supporting both reverse and hammer grip training modes - reverse grip targets biceps while hammer grip precisely strengthens the brachialis. Each grip angle is precisely calculated, ensuring absolute safety and optimal force output.

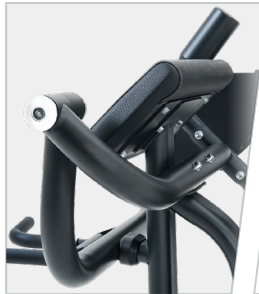

Precise Arm Pad Angle, Eliminating Compensation

The precisely engineered arm pad angle cleverly guides anterior deltoid pre-contraction, effectively preventing compensatory movements. The ergonomic pad design provides stable, comfortable support, allowing users to focus purely on biceps contraction sensation.



Pneumatic Rod Adjustment, Ultimate Training Experience

The seat features premium pneumatic adjustment, eliminating traditional adjustment mechanism sticking points. Single-handed adjustment saves time and effort, while the innovative rack-and-pinion locking structure delivers rock-solid training stability.