

RE80 SELECTORIZED SERIES**RE8005 - MULTI PULLEY ROW****PRODUCT OVERVIEW**

Introducing the Adjustable Seated Row Machine - unleash your back's full potential. The oversized footplate provides rock-solid support, while the 10-position height-adjustable pulley system targets every angle of your back. Featuring a precision cast iron weight stack system starting at 5kg with 2.5kg micro-adjustment plates, ensuring every workout is perfectly calibrated!

SPECIFICATIONS & KEY FEATURES

Specifications

Dimension	2144*1445*1800mm
Total Weight:	238kg
Weight Stack:	105kg
Max Weight Stack:	117.5kg

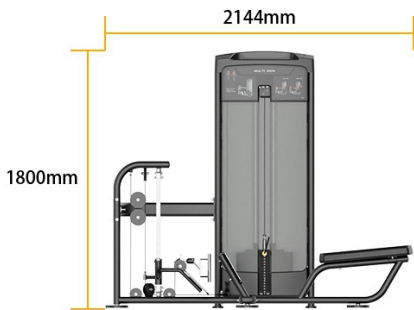

Product Features



10-Position Height Adjustment, No Back Muscle Left Behind

Revolutionary 10-position pulley height adjustment breaks traditional fixed-position training limitations. Whether you're targeting your teres major, latissimus dorsi, trapezius, or any other back muscle, precise targeting is at your fingertips!



Oversized Footplate, Rock-Solid Stability

The oversized footplate significantly increases foot support area, delivering unprecedented stability. Footplate height and angle have been extensively tested across a large sample size, ensuring users of all body types experience rock-solid training stability.



Innovative Storage Design, Maximum Convenience

Equipped with 4-position training attachment hooks, solving traditional back training handle storage challenges. The user-friendly storage layout ensures handles are within easy reach during training while maintaining an organized training space.



Extended Seat Pad, Full Range of Motion

Full range of motion is essential for muscle growth. The widened and extended seat pad enables maximum stretch and contraction sensation in seated rowing exercises, creating optimal conditions for back muscle development!