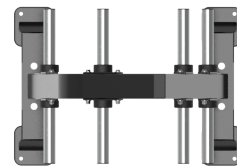

**DH PLATE LOADED SERIES****DH011-WEIGHT PLATE TREE****PRODUCT OVERVIEW**

The DH011 is a heavy-duty storage rack designed specifically for organizing weight plates. Featuring a modern aesthetic and solid construction, it is built with high-strength carbon steel for maximum durability and safety in commercial gym environments. Each side includes three plate pegs, with tiered spacing optimized through precision engineering to prevent interference between plates, allowing for easy access and neat storage. The base is equipped with an adjustable leveling foot to ensure stability on uneven flooring, minimizing wobble during use.

# SPECIFICATIONS & KEY FEATURES

## Specifications

Dimension:	908*638*1238mm
Net Weigh:	42kg

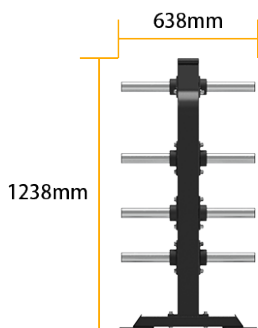
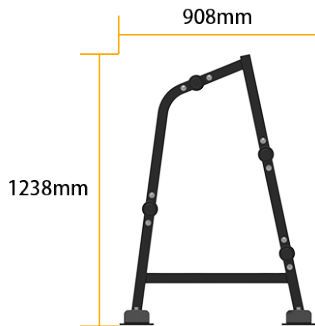
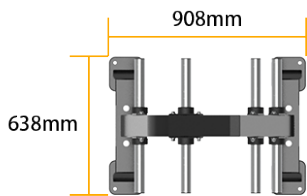

## Product Features



### Heavy-Duty Carbon Steel Frame

Built for long-lasting strength and safety in high-use environments.



### Four Pegs per Side with Tiered Spacing

Optimized height spacing prevents interference and ensures convenient loading and unloading.