

**RE80 SELECTORIZED SERIES****RE8003 - PECTORAL FLY/REAR DELTOID****PRODUCT OVERVIEW**

Introducing the Pectoral Fly & Rear Deltoid Combo Machine - your ultimate solution for chest and posterior deltoid training. Featuring a multi-position adjustable arm system and dual-handle design, seamlessly switch between pectoral fly and reverse fly exercises. The 6-position backrest adjustment paired with a pneumatic seat system perfectly accommodates users of all body types.

# SPECIFICATIONS & KEY FEATURES

## Specifications

Dimension	1499*1326*2024mm
Total Weight:	246kg
Weight Stack:	105kg
Max Weight Stack:	117.5kg

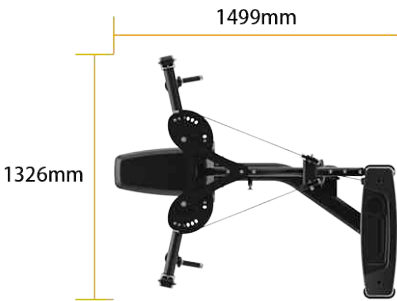
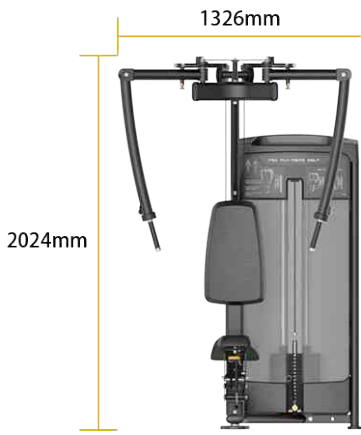

## Product Features



### Biomechanical Masterpiece, Dual-Function Training Redefined

The multi-position adjustable arm system enables effortless transitions between seated pectoral fly and reverse fly movements. With 5 precision adjustment settings, experience comprehensive muscle engagement for both pectoral and posterior deltoid muscles. The movement arm is crafted from high-strength steel, ensuring reliable stability and durability.



### Dual-Handle Design, Breaking Muscle Contraction Limits

The ergonomically engineered dual-handle system with specialized coating technology delivers superior grip comfort. Horizontal handles feature slight internal rotation while vertical handles incorporate subtle external rotation, ensuring every ounce of force precisely targets the pectoral and posterior deltoid muscles.



### Pneumatic Micro-Adjustment Technology, Precise Training Control

Want to target different angles of your chest and rear deltoid muscles through backrest adjustments? No problem! The 6-position backrest adjustment, pneumatic seat adjustment, and extended seat design enable precise control over training postures. All adjustments can be completed with one hand, maximizing efficiency and convenience.



### Precision Weight Stack Engineering, Professional Training Assurance

Utilizing a high-density cast iron weight stack system with specialized black textured powder coating for premium feel. The 5kg base weight combined with 2.5kg\*2 micro-adjustment plates meets progressive training requirements. Special protective coating ensures wear and corrosion resistance, providing lasting durability for professional training.